



MT CELL SETUP MANUAL

MT556XNB

Copyright ©2018 MultiTaction. All rights reserved.

This user manual is intended for the owners and operators of MultiTaction Cell products. It contains guidelines for the proper usage of the products. Information in this manual is subject to change without prior notice to product owners. For the latest product details and guidelines please visit the product website.

Trademarks

MultiTaction, Cornerstone, Codice, MT Canvas and MT Showcase are trademarks or registered trademarks of MultiTaction.

All other trademarks are the property of their respective owners.

Safety Information

Read through carefully and understand all the safety information before installing or using the product. Follow the instructions in this manual and marked on the MultiTaction Cell. Take careful notice of all warnings and safety-related instructions to install and use the product safely.

 **Danger:** *Indicates a hazard with a high level of risk which, if not avoided, will result in death or serious injury AND / OR property damage.*

 **Warning:** *Indicates a hazard with a medium level of risk which, if not avoided, could result in death or serious injury AND / OR property damage.*

 **Caution:** *Indicates a hazard with a low level of risk which, if not avoided, could result in minor or moderate injury AND / OR property damage.*

 **Note:** *Indicates important information.*

Consignes de sécurité

Etudier soigneusement et bien comprendre toutes les consignes de sécurité avant d'installer ou d'utiliser le produit. Respecter les instructions fournies dans ce manuel et celles marquées sur la MultiTaction Cell. Bien tenir compte de tous les avertissements et des instructions de sécurité afin d'installer et d'utiliser le produit en toute sécurité.

 **Danger:** *Indique un danger avec un niveau de risque élevé qui, s'il n'est pas évité, peut causer la mort ou une blessure grave ET / OU des dommages matériels.*

 **Avertissement:** *Indique un danger avec un niveau de risque élevé qui, s'il n'est pas évité, peut causer la mort ou une blessure grave ET / OU des dommages matériels.*

 **Attention:** *Indique un danger avec un niveau de risque bas qui, s'il n'est pas évité, peut causer des blessures mineures ou légères ET / OU des dommages matériels.*

 **Remarque:** *Contient des informations importantes.*

Regulatory information

European Union Directive on Restriction of Hazardous Substances (RoHS)

This MultiTaction Cell complies with the following regulatory standards:

- RoHS
- FCC vol 47 part 15
- ICES-003 Issue 6
- EN 55032: 2015
- EN 55024: 2010 + A1: 2015
- IEC 61000-3-2: 2014
- IEC 61000-3-3: 2013
- IEC 62471A: 2006
- IEC60950-1: 2005 (ed.2)+A1: 2009+A2: 2013
- UL60950-1 part 1
- CAN/CSA C22.2 No. 60950-1-07 part 1

For more compliance information, please provide MultiTaction with the serial number of the MultiTaction Cell.

Disposal Guidelines

The MultiTaction Cell complies with the European RoHS -directive. Please consult local authorities and professionals when planning to dispose of the Cell.

Contents

Contents	4
1 Introduction	6
1.1 MultiTaction support.....	6
2 Cell overview	7
2.1 Cell technologies.....	7
2.2 Dimensions and 3D models.....	8
2.2.1 MT556XNB.....	8
2.3 Connection panel.....	9
2.3.1 MT556XNB.....	9
2.4 Warning labels.....	10
3 Unpacking the Cell	11
3.1 What's in the box?.....	11
3.2 Unpack the cardboard box.....	11
4 Before you start	13
4.1 Proper environment.....	13
4.2 Normal operating conditions.....	13
4.3 Ventilation and heat management.....	14
5 Get the Cell into position	16
5.1 Mounting an MT556XNB.....	17
5.2 Custom table installation.....	19
5.2.1 Custom table with installed Cell.....	20
5.2.2 Custom enclosure with installed Cell.....	21
5.2.3 Custom enclosure with separate space and ventilation system for computer unit.....	21
5.3 Desk stand installation.....	22
5.4 Multiple-Cell installation.....	23
5.4.1 Display wall installations.....	25
6 Connect the Cell	26
6.1 Connections to the mains power supply.....	26
6.2 Connections to an external application computer.....	28
6.3 Connections to the internet.....	28
6.4 USB mouse and keyboard.....	29
6.5 Connections to the SYNC IN / OUT.....	29
7 Start up the Cell	30
8 Set up the tracking engine	31
9 Setting up the application computer	32
10 Maintenance and cleaning	33
10.1 Prevent screen burn-in.....	33
10.2 Cell maintenance or repair.....	33
10.3 Cleaning the Cell.....	34
10.4 Warning to service personnel.....	35

10.5 Replaceable battery.....	35
Appendix A. Technical specifications	36
A.1 Display.....	36
A.2 Touch sensing hardware	36
A.3 Interfaces	36
A.4 Electrical specifications	37
A.5 Power consumption	37
A.6 Touch details.....	37
A.7 Environment	38
A.8 Dimensions and weight	38
A.9 Display mounting.....	38
A.10 Cooling.....	39
A.11 Ventilation	39
A.12 Miscellaneous.....	39
FCC compliance	40
Warranty service policy and procedures	41

1 Introduction

MultiTaction Cells (or *MT Cells*) are multi-touch, modular LCD displays intended for, but not limited to, retail businesses, advertising, exhibitions, museums, education, and design installations.

‘Multi-touch’ means that Cells can track and react to several people interacting with them simultaneously. Moreover, the system tracks a person’s hands instead of points of contact only, further enhancing interactive possibilities. ‘Modular’ means that Cells can be easily stacked and combined to form a video wall (a single large display array), showing interactive content and reacting to multiple users’ touch.

The LCD displays deliver full HD picture quality, have a long life-span, and need hardly any maintenance. Current models also have an Extreme-Narrow Bezel (XNB).

Cells need an external computer for running the applications. You can work on Linux, OS X, or Windows environments, and create your own tailored apps through the MultiTaction Cornerstone SDK or many other supported methods.

This manual contains installation and operating instructions for MultiTaction 55” Cells. It covers model MT556XNB.



MultiTaction Cell MT556XNB

1.1 MultiTaction support

If you need technical assistance, please contact MultiTaction Support:

<https://www.multitaction.com/support-services>

2 Cell overview

 **Note:** For full technical specifications, see [Appendix A](#).

 **Remarque:** Pour des spécifications techniques complètes, voir [Appendix A](#).

MultiTaction is an innovative way to build an integrated multi-touch LCD display. The front glass and LCD package is tuned to allow the integrated optical imaging system to work effectively through it. Imaging logic and processing power are embedded in the display unit. The diagram below shows the main components used in MultiTaction Cells.

2.1 Cell technologies

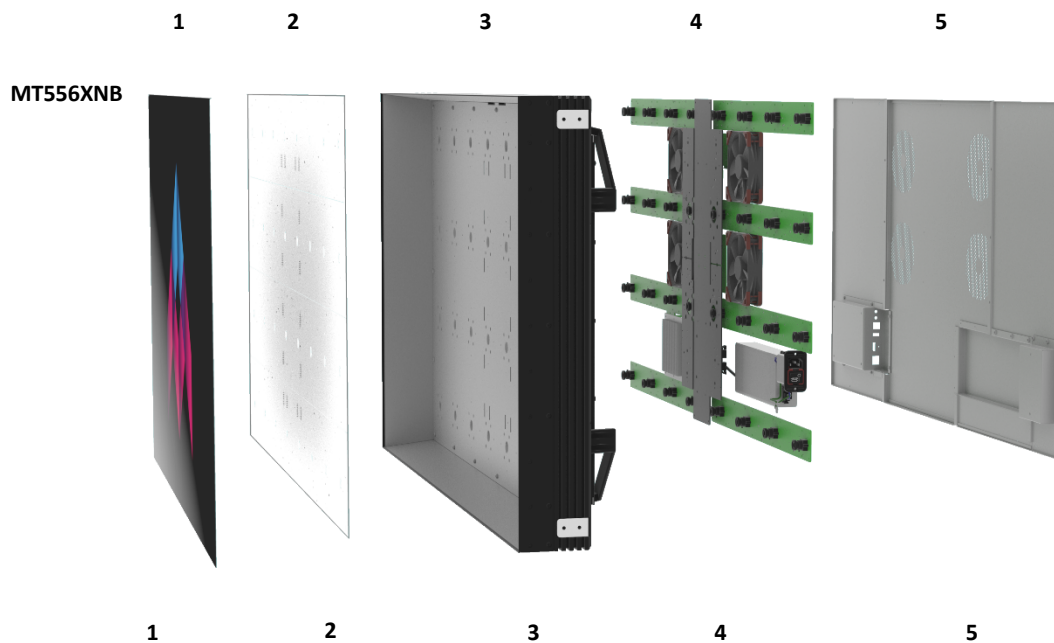

Cell technologies

- 1 LCD panel. Uses ClearSight touch technology.
- 2 Backlight.
- 3 Aluminium frame and backlight cooling channel
- 4 Electronics, including:
 - Extensible Hybrid Tracking Engine (EHTE) i.e., the core tracking technology
 - Matrix Tracking System (MTS), comprising 32 distributed cameras
- 5 Back plate

2.2 Dimensions and 3D models

2.2.1 MT556XNB

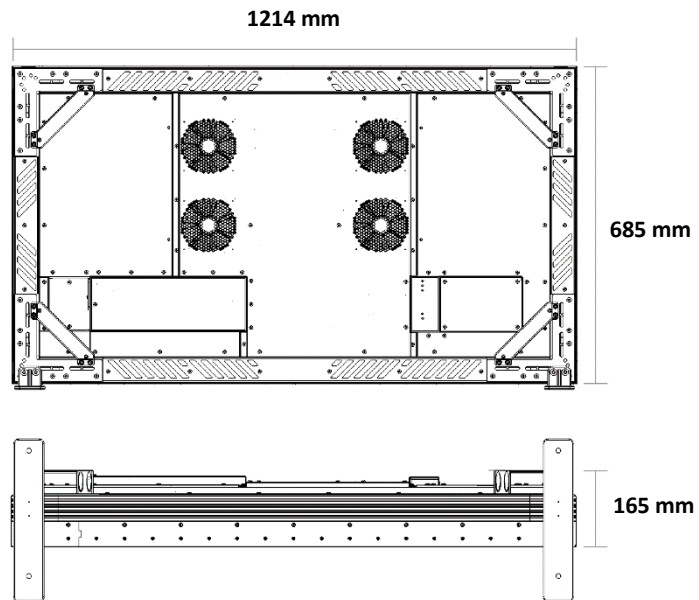

Outer dimensions: MT556XNB

2.3 Connection panel

The Cell connection panel is located at the back of the device. It contains the power switch and sockets for connecting the Cell to: your network or an external application computer; a power supply; and a local mouse and keyboard.

2.3.1 MT556XNB

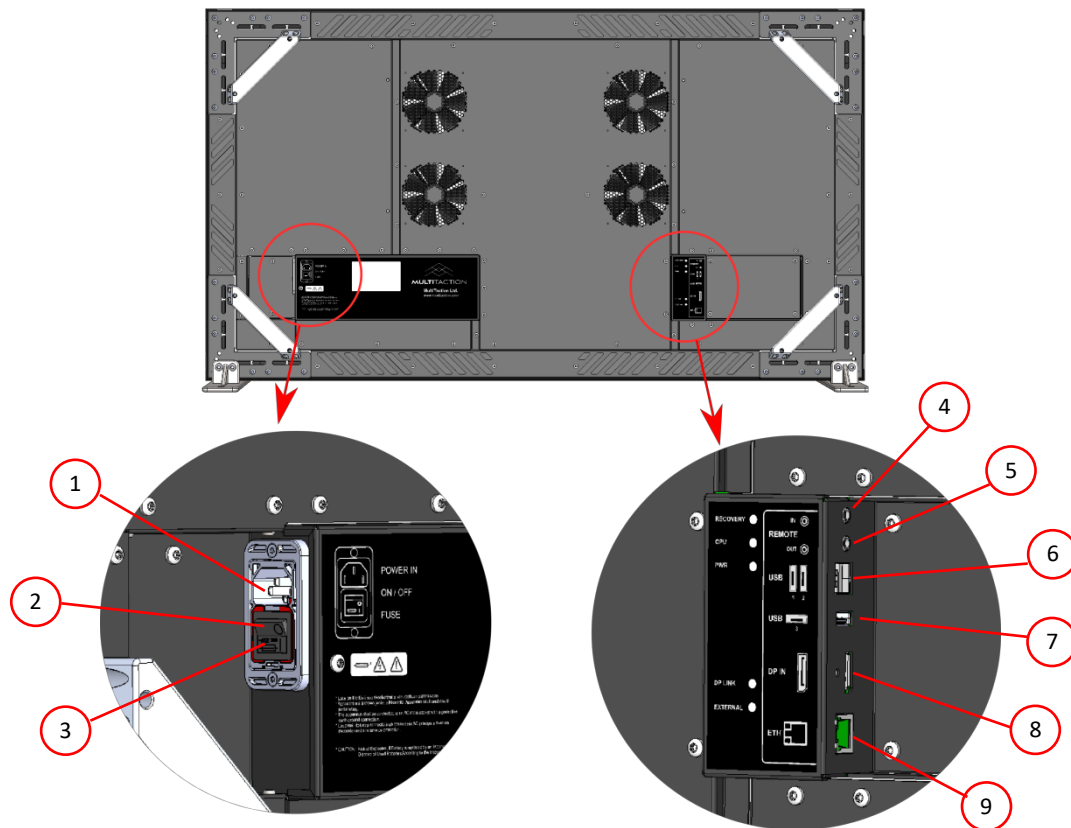

Cell connection panel. Includes the following sockets and controls

- | | | |
|---|--------------------|---|
| 1 | Mains | Power connection to the mains supply. |
| 2 | Power switch | Main on / off switch |
| 3 | Two fuses | Mains voltage fuse |
| 4 | 3.5mm socket | Sync IN to control IR operation |
| 5 | 3.5mm socket | Sync OUT to control IR operation |
| 6 | 2 x USB 2.0 Type A | Two ports for peripheral devices, especially keyboard and mouse |
| 7 | USB 2.0 Type A | Port for peripheral devices |
| 8 | DisplayPort | Digital signal input |
| 9 | Ethernet | For control input |

2.4 Warning labels

The following warning labels can be found on or inside the Cell:

Warning: Product label

- ❗ *Laite on liitettävä suojakoskettimilla varustettuun pistorasiaan.*
- ❗ *Apparatet må tilkoples jordet stikkontakt. Apparaten skall anslutas till jordat uttag.*
- ❗ *The apparatus shall be connected to an AC main socket with a protective earth ground connection.*
- ❗ **Avertissement:** *L'appareil doit être connecté à un connecteur AC principale avec un raccordement à la terre de protection.*

⚠ **Caution:** *Risk of Explosion, if Battery is replaced by an Incorrect Type. Dispose of Used Batteries According to the Instructions.*

⚠ **Attention:** *Risque d'explosion si les piles sont remplacées par d'autres piles de type incorrect. Jeter les piles usagées selon les instructions.*

- Used only at altitudes not more than 2000 m above sea level.
- Used only in non-tropical conditions.

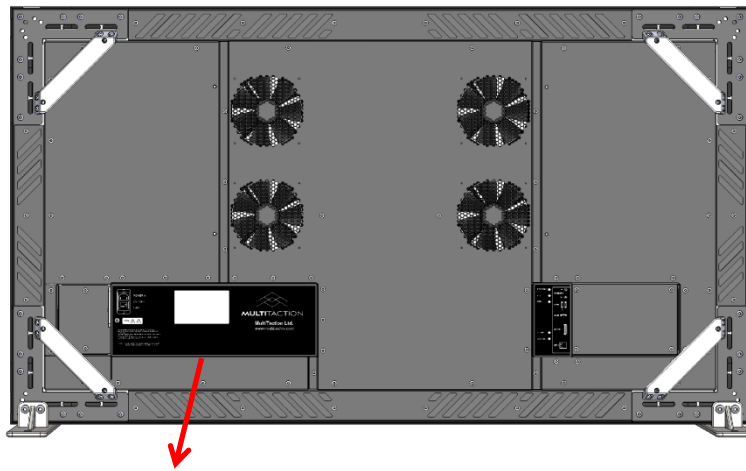

POWER IN
ON / OFF
2 x FUSE

Made in Finland 芬兰制造

P/N: MT0901091	S/N:
Model: MT556XNB 型号:	Rev:

Power Rating: 100 - 240VAC, 5 - 2.8A, 50/60Hz
Fuse: 2 x 6.3AT

CE cUL US LISTED I.T.E. E600000

Manufacturer / 制造商: Multitaction Ltd.
CAN IECS-3 (B) / NMB-3 (B)

MULTITACTION

Multitaction Ltd.
www.multitaction.com

* Laite on liitettävä suojakoskettimilla varustettuun pistorasiaan.
* Apparatet må tilkoples jordet stikkontakt. Apparaten skall anslutas till jordat uttag.
* The apparatus shall be connected to an AC main socket with a protective earth ground connection.
* L'appareil doit être connecté à un connecteur AC principale avec un raccordement à la terre de protection.
* 设备必须与带有保护接地装置的插座连接。
* CAUTION: Risk of Explosion, if Battery is replaced by an Incorrect Type. Dispose of Used Batteries According to the Instructions.
* 警告: 如果电池更换类型不正确, 则有爆炸的危险。根据说明处理废旧电池。

* Used only at altitudes not more than 2000m above sea level
* 仅适用于海拔2000m以下地区安全使用

* Used only in non-tropical conditions
* 仅适用于非热带气候条件下安全使用

Warning labels on rear of Cell: **1** Product label.

3 Unpacking the Cell

The Cell is delivered in a specially designed cardboard box to secure it during transportation.

You need two people to remove the Cell from its box, one person lifting from each side. Make sure you have enough space around the cardboard box to lift the Cell and position it in the desired location.

3.1 What's in the box?

MultiTaction Cell product box contains the following items:

- MultiTaction Cell
- A pair of desk stands
- Power Cords 3 m (EUR, US, GB)
- Digital video cable 3 m (Display Port)
- Ethernet cable 3 m (Cat6)
- English user manual

Carefully check that you have received all the items before proceeding to install the Cell. If your product box is missing an item, please contact your dealer.

3.2 Unpack the cardboard box

To unpack the Cell from its cardboard shipping box, place the shipping box on a clean floor. Then:

1. Cut the packing straps.
2. Open the top lid and
3. centre of the box.

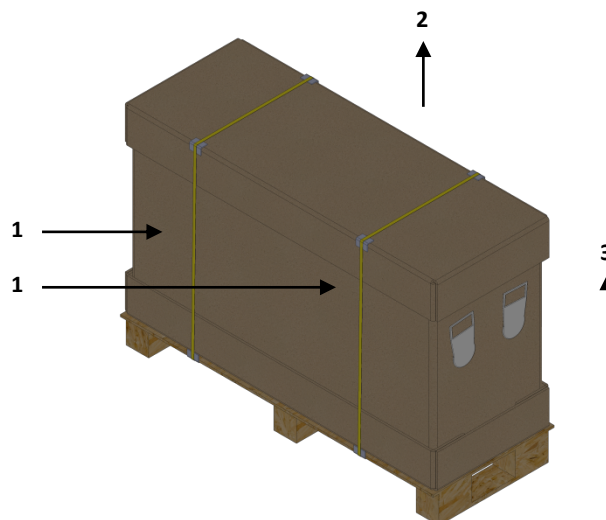

1 Packing straps. **2** Remove the top part of the box. **3** Remove the centre part of the box.

4. Remove the protective Cell top paddings (item 3 in the fig.).
5. Remove the Cell from the container with help from another person, one lifting from each side (item 4 in the fig.).

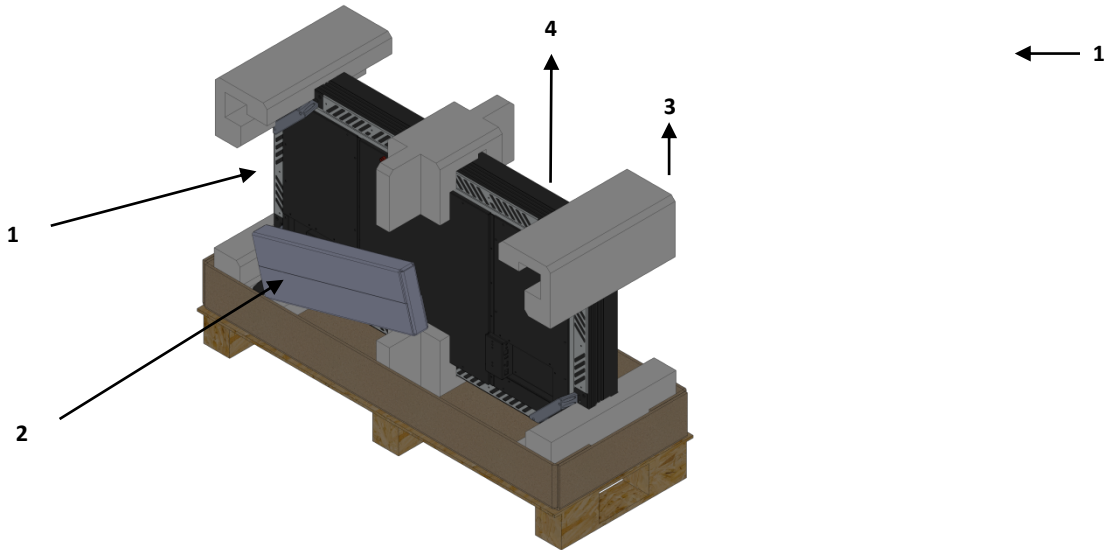

1 Cell. 2 Accessories box. 3 Remove the paddings. 4 Remove the Cell.

6. Instructions for careful handling.

- ⚠ **Caution:** Never rest the Cell on its edge.
- ⚠ **Attention:** Ne jamais la Cellule reposer sur son bord.

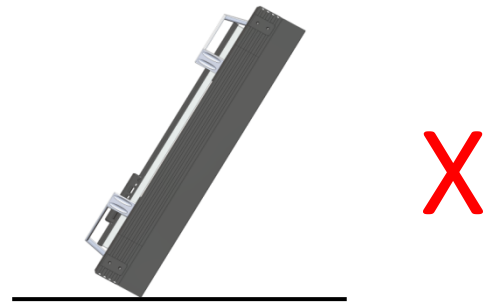

- ⚠ **Caution:** Never rest the Cell on its LCD Screen.
- ⚠ **Attention:** Ne jamais laisser la Cellule reposer sur son Écran LCD.

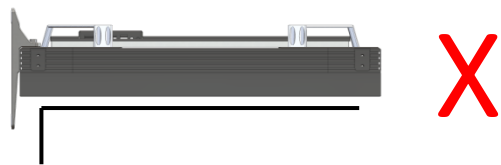

- 📄 **Note:**
 - Place over a table when remove the legs.
 - Lift only by the handles.

- 📄 **Remarque:**
 - Mettre sur une table en retirant les pieds.
 - Soulever seulement par la poignée.

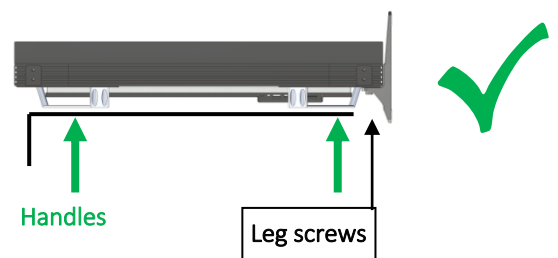





4 Before you start





4.1 Proper environment

Choose a well-ventilated, cool space for setting up the display.

Caution:

-  Radiating heat sources (like halogen spots) can damage the display.
-  Keep the Cell away from strong spot-light areas.
-  Intense sunlight can damage the display.
-  Place the Cell in a space where intense sunlight does not hit the display area (front panel).

Attention:

-  Les sources de dégagement de chaleur rayonnée (notamment les lampes halogènes) peuvent endommager l'écran.
-  Maintenir la Cellule éloignée des zones à forte source de lumière.
-  Une lumière solaire intense peut endommager l'affichage.
-  Placer la cellule dans un endroit où les rayons solaires intenses n'atteignent pas l'affichage (panneau avant).

4.2 Normal operating conditions

MultiTaction Cells are designed to operate normally for extended periods of time (up to 20 hours per day). Using a Cell under normal operating conditions ensures maximum performance.

The following table contains the normal operating conditions for Cells.

Condition	Correct parameters
Temperature	0° to 35° C (32° to 95° F). Optimal performance 20° to 25° C (68° to 77° F)
Humidity	Non-condensing < 80% RH
Display pattern	A moving picture or regularly changing animation
Sunlight	No intense sunlight on the display area (front panel)
Infrared sources	Do not use in the vicinity of strong spot-light areas or other strong infrared sources
Radiating heat	Do not use in the vicinity of strong radiating heat sources
Dust	Clean dust-free environment

Caution:

- ⚠ *Using the Cell under other than the Normal Operating Conditions may reduce the lifetime of the Cell.*
- ⚠ *To reach the lifetime specification of the Cell always, use it under the Normal Operating Conditions.*

Attention:

- ⚠ *Le fait d'utiliser la Cellule qui ne se trouve pas dans un État de fonctionnement normal peut réduire la durée de vie utile de la Cellule.*
- ⚠ *Pour toujours atteindre la spécification de durée de vie utile de la Cellule, utiliser celle-ci dans des États de fonctionnement normaux.*

4.3 Ventilation and heat management

Heat build-up reduces lifetime and operating safety of the device and can cause hardware failure. It is essential that you control a Cell's exposure to heat.

Ventilation and heat management are especially important in a multiple-Cell installation. You must ensure there is adequate airflow (cool air in and hot air out) through the ventilation slots on each Cell. In particular, ensure that hot air vented from Cells is directed away from the cool air intakes of adjacent Cells; see the example in [section 5.4.1](#).

To ensure proper heat management, review the following checklist.

Item	Correct status
Ventilation	Ensure the Cell is installed in a well-ventilated environment and in a well-ventilated enclosure (if enclosure is used). The device is not covered with clothes, papers, props or other materials which can prevent the proper ventilation of the device.
Operating temperature	Ensure that temperature is within the normal operating limits in section 4.2 .
External factors	Ensure there are no external factors heating the Cell above the temperature limits. External factors can include for example direct sunlight, spotlights or other heat emitting devices.
Installation clearance	<p>Ensure the gap (or clearance) between the Cell and wall, or between the Cell and base of the enclosure, matches the <i>minimum safe distance</i>.</p> <ul style="list-style-type: none"> ▪ For single Cells, this is at least the distance from the back side of Cell to outside of the handles 51 mm (2 in) ▪ For multiple-Cell displays, this is at least 51 mm (2 in) <p>See also section 5.2.2 and section 5.4.</p>
Air Flow Channels	<p>Channels flow the warm air towards the sides of the Cell. Air Flow Channels are used when</p> <ul style="list-style-type: none"> ▪ the Cell position is display direction up (table installation) or ▪ in the multiple-Cell installations. <p>See also section 5.2 and section 5.4</p>

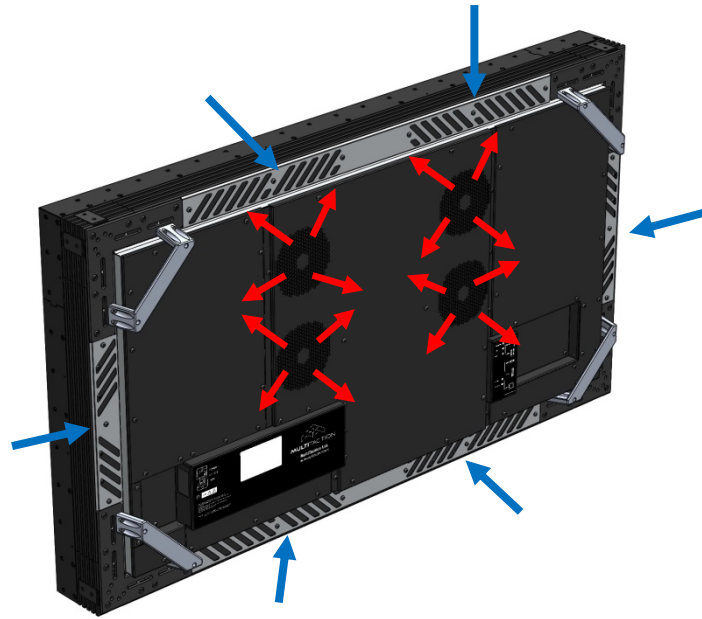

VENTILATION:
COOL AIR IN from sides of cell

VENTILATION:
WARM AIR OUT from center of cell

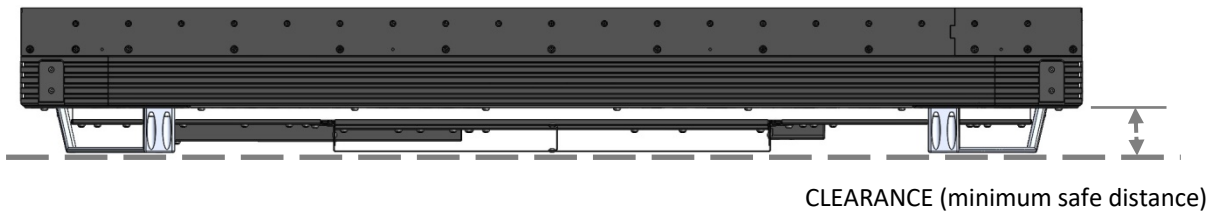

Ventilation slots and clearance. The clearance must match the minimum safe distance.

If you have specific installation requirements (for example, if your installation design requires a reduced clearance), please contact MultiTaction Support for advice; see [section 1.1](#).

See also the warnings on page 26.

Caution:

- ⚠ *Make sure that the cooling and air ventilation properties of the installation location meet the requirements of the Cell.*
- ⚠ *Keep the ventilation slots free of blockages at all times. Leave enough space around the Cell to allow proper air circulation and cooling between the display and walls or panels:*

Attention:

- ⚠ *S'assurer que le refroidissement et la ventilation du local d'installation sont conformes aux exigences de la Cellule.*
- ⚠ *Faire en sorte que les événements ne soient jamais obstrués. Laisser suffisamment d'espace autour de la Cell, pour permettre à l'air de circuler et au refroidissement de se faire entre l'écran et les murs ou panneaux:*

5 Get the Cell into position

MultiTaction Cells must be installed before use. Follow the guidelines below:

- Mounting an MT556XNB; see [section 0](#).
- Custom table installation; see [section 5.2](#).
- Desk stand installation; see [section 5.3](#).
- Multiple-Cell installation; see [section 5.4](#).

Before installing, ensure the operating environment is suitable for the Cells; see [section 4](#).

For detailed instructions and support contact MultiTaction Customer Success team, see section 1.1.

Caution: *Important when mounting a Cell, remember that:*

- ⚠ *Screws can enter the panel up to 14 mm in depth in the corner mounting holes (see mounting point 1 in the following figure), no more depth accepted.*
- ⚠ *Use M8 screws with steel grade 12.9 to guarantee proper stencil strength. Tighten screws to torque value 20Nm.*

Attention:

- ⚠ *Les vis peuvent entrer dans le panneau jusqu'à 14 mm de profondeur dans les trous de fixation aux coins (voir le point de fixation 1 dans la figure suivante), une plus grande profondeur sera refusée.*
- ⚠ *Utiliser des vis M8 avec une nuance d'acier de 12,9 pour garantir une bonne résistance à la traction. Serrer les vis à une valeur de couple de 20 Nm.*

Warning:

- ⚠ *Use handle mounting points only in table installations (ref. chapter 5.2), not in multiple-cell installation (ref. chapter 5.4).*
- ⚠ *Cells are heavy. The MT556XNB weighs 35kg.*

Avertissement:

- ⚠ *Utiliser les points de fixation de poignée uniquement dans les installations de tables (réf. chapitre 5.2), et pas dans l'installation de plusieurs cellules (réf. chapitre 5.4).*
- ⚠ *Les cellules sont lourdes. The MT556XNB pèse 35 kg.*

5.1 Mounting an MT556XNB

The MT556XNB offers highly flexible mounting options. In each corner, there are five M8, 14 mm deep screw holes. See mounting point 1 on the following figure.

When mounting MT556XNB to any mounting bracket, use M8 screws with steel grade 12.9. Tightening torque is 20Nm. Never use too long screws that could bottom the 14mm deep mounting screw holes.

Mounting holes are also used for MT556XNB legs. Leg screws are M8 x 20mm with steel grade 12.9. These M8 x 20mm leg screws can be used mounting MT556XNB to mounts that have minimum thickness of 6mm and maximum thickness of 12mm. Tightening torque is 20Nm. If mounting bracket thickness is less than 6mm, a shorter M8 x 16mm with steel grade 12.9 must be used.

If you want to use the MT556XNB on a table mount, an optional adapter can be fitted to the handles in each corner. See point 2 on following figure. These handles are not suited for any other than table mounting.

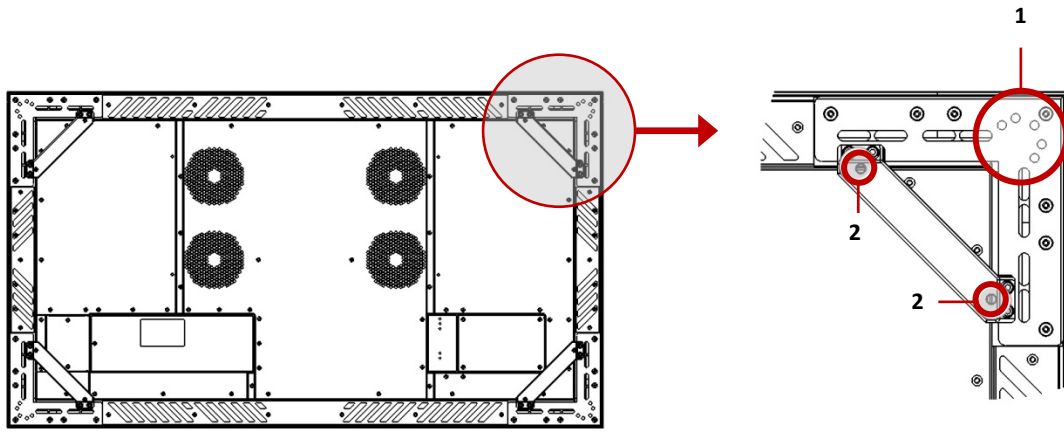

MT556XNB rear view. The following screw holes are with M8 thread and they are repeated in each corner:

Point 1: *Five screw holes (with M8 thread) on the corner.*

Point 2: *Two screw holes (with M8 thread) on handles, used only for custom table installation.*

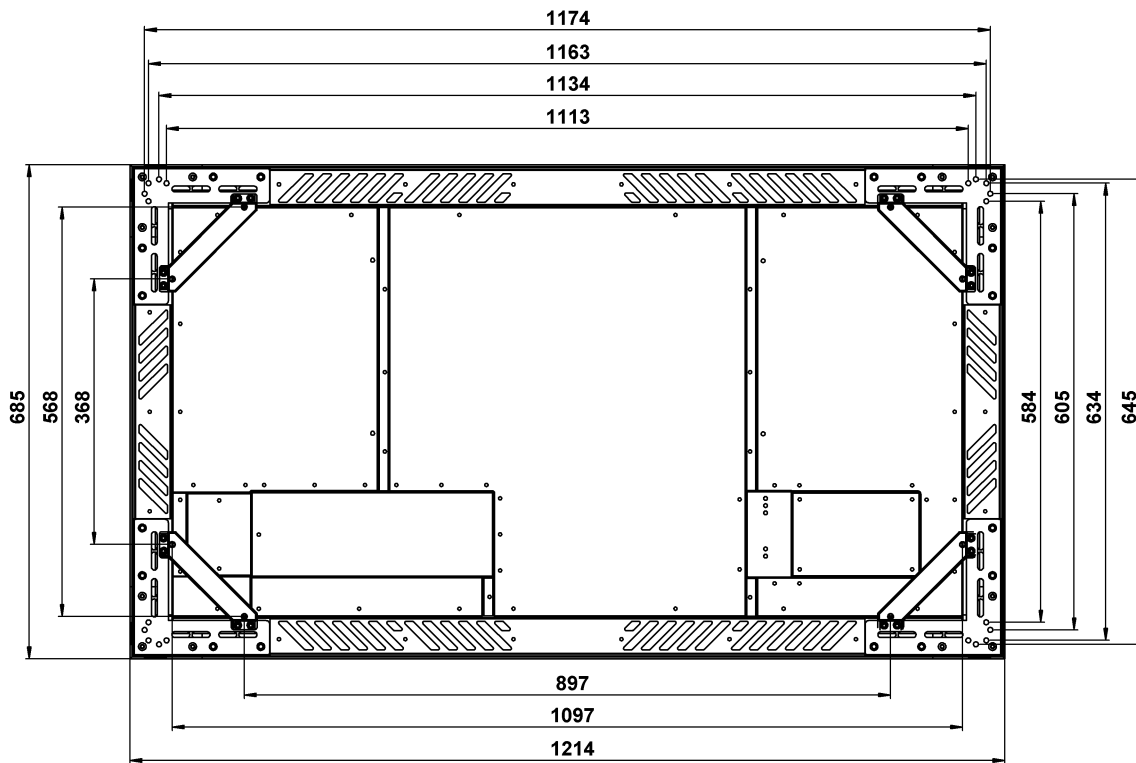

MT556XNB rear view. Screw hole locations.

5.2 Custom table installation

A Cell can be installed as a table in a horizontal or tilted position, or in a custom enclosure.

A Cell is attached to the enclosure by the rear panel corner or handle M8 screw holes.

A simplified custom setup would consist of sturdy supporting legs on each side, firmly wrapping the Cell and keeping it at the *minimum safe distance limited by handles* from the top of a stable surface.

To complete a custom installation, follow these steps:

1. Prepare the custom table or enclosure for the Cell.
2. Ensure that the Cell has sufficient ventilation (cool air in, hot air out). See the diagrams in [section 5.2.2](#) and [section 5.2.3](#).
3. MultiTaction Air Flow Channels has to be used in the displays on table installations.
4. Locate the M8 type screw holes. Note maximum 14 mm screw depth in the corner M8 mounting holes.
5. Use M8 steel screws with steel grade 12.9 (ref. chapter 5).
6. Firmly attach the Cell with 20Nm torque to the custom table or enclosure using M8 screws and the Cell's screw holes. Ensure the Cell is correctly aligned.

Warning:

- ⚠ *Never install a Cell inside a fully enclosed space! Risk of device overheating, which can lead to critical hardware failure and personal injuries.*

Ensure the custom enclosure design complies with the minimum safe distance between the Cell underside and the base of the enclosure to allow sufficient air ventilation (cool air in, hot air out).

- ⚠ *Loosely installed Cell may fall and cause personal injuries.*
Attach the Cell properly by the M8 screw holes. If the Cell is installed in a public environment, check the condition of the enclosure and attachments regularly.

Avertissement:

- ⚠ *Ne jamais installer la Cellule dans un espace entièrement clos! Risque de surchauffe du dispositif pouvant causer une panne critique du matériel et des blessures corporelles.*

S'assurer que les dimensions et le montage du dispositif d'utilisation conforment avec les distances de sécurité requises, au dessus d'une surface stable, et que la Cellule a son propre système de ventilation (entrée d'air frais, sortie d'air chaud).

- ⚠ *Une Cellule qui n'est pas montée solidement peut tomber et causer des blessures corporelles.*
Attacher la Cellule correctement par les trous de vis M8. Si la Cellule est installée dans un milieu public, contrôler régulièrement la condition du boîtier et des fixations.

 **Note:** Any unauthorized modification of the Cell will void warranty.

 **Remarque:** Toute modification non autorisée de la Cellule invalidera la garantie.

5.2.1 Custom table with installed Cell

VENTILATION:

WARM AIR OUT from center of cell

VENTILATION:

COOL AIR IN from sides of cell

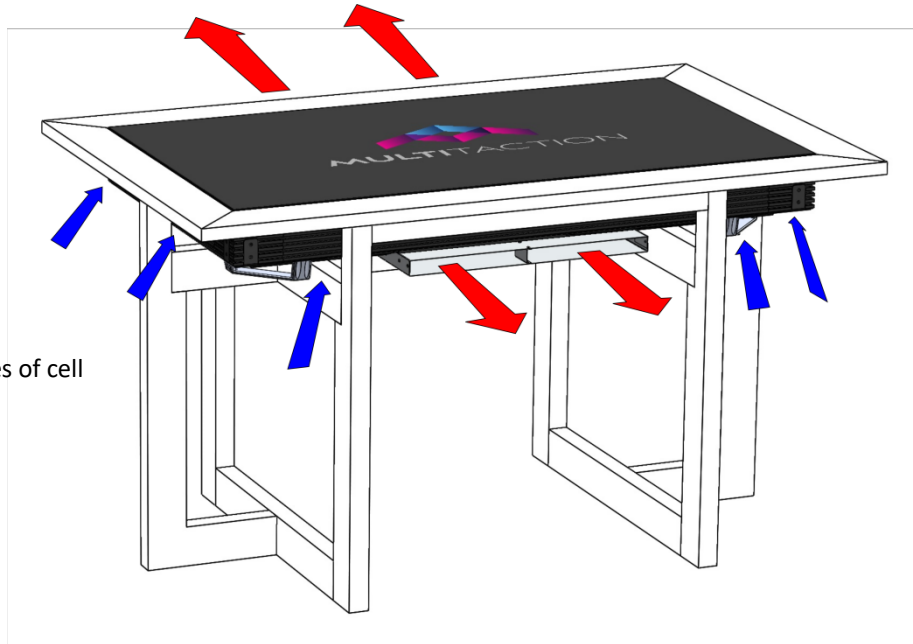

Custom table with installed MT556XNB

Ensure that the clearances between the display side and table, and between the LCD surface and surrounding table surface, do not exceed 2mm. The table should protect the edge of the display.

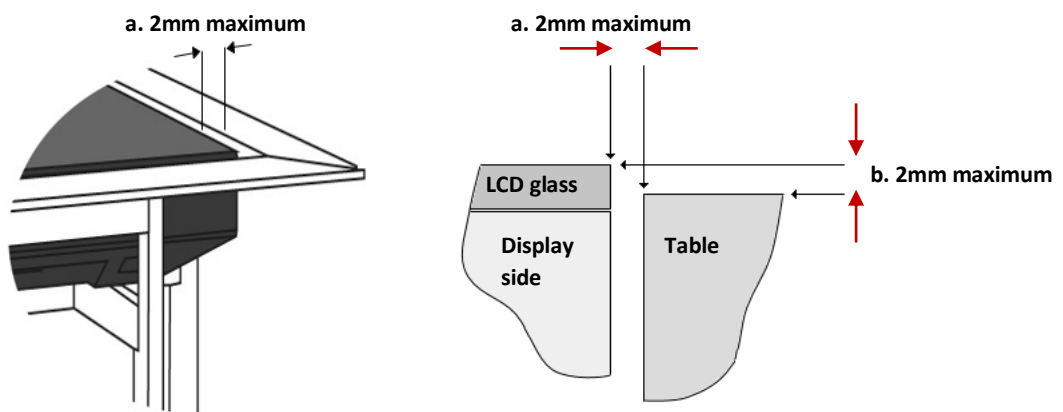

MT556XNB: Maximum table clearances

a. Maximum 2mm gap between display side and table

b. Maximum 2mm difference between LCD surface and table surface

5.2.2 Custom enclosure with installed Cell

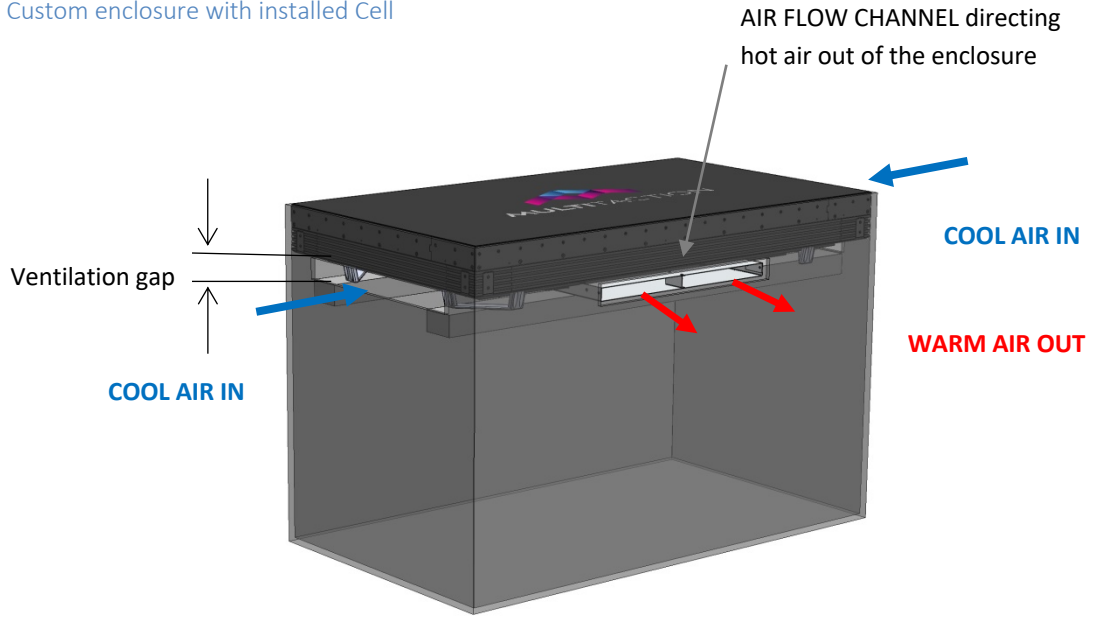

Custom enclosure with installed MT556XNB. Note the ventilation gap below the Cell to allow sufficient cool air to flow in.

5.2.3 Custom enclosure with separate space and ventilation system for computer unit

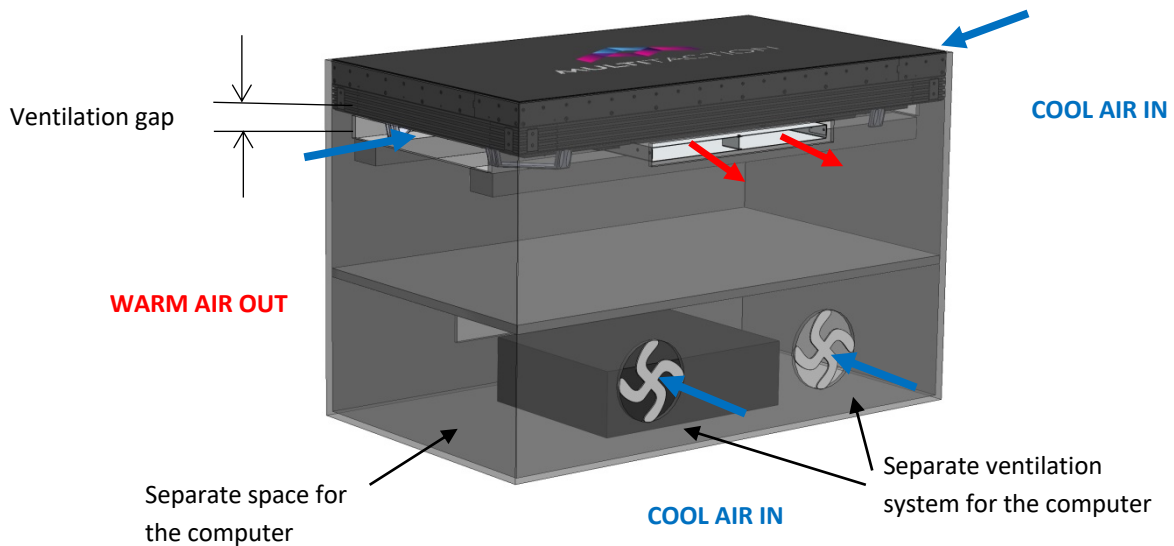

Custom enclosure with separate space and ventilation system for computer unit. Note the ventilation gap below the Cell to allow sufficient cool air to flow in.

5.3 Desk stand installation

The MultiTaction Cell comes with a pair of desk stands. Desk stands ensure safe and stable installation when the Cell is positioned horizontally or vertically on a sturdy desk or table.

1. Choose a sturdy desk for the installation and the surface of table is horizontal. Ensure the desk can bear the weight load of the Cell (35 kg / 77 lbs) and that the desk will not tip over when the Cell is installed.

! **Warning:** *Using a desk that is too weak, installing the desk stands incorrectly, or installing into an incorrect position, causes a risk of the Cell tipping over, property damage and personal injuries. To avoid this risk, choose a desk with a heavy enough structure for the installation, install the desk stands according to this manual and ensure that desk will not tip after the installation.*

! **Advertissement:** *Si la table utilisée est d'une structure trop légère ou si celle-ci est mal soutenue ou installée dans une mauvaise position, la Cellule risque de se renverser et de causer des dommages matériels ou personnels. Pour éviter ce risque, choisir une table de structure suffisamment solide pour l'installation, monter la table selon les instructions de ce manuel et s'assurer que la table ne puisse pas s'incliner après l'installation.*

2. Depending on the Cell orientation (horizontal or vertical), place the cell on the stands on the desk and attach them with M8 screws to the rear of the display. Desk stands can be mounted on the table with two screws.

! **Warning:** *To minimize the risk of tipping, do not place the stands on the edge of the desk.*

! **Advertissement:** *Pour atténuer le risque de renversement, ne pas mettre les supports sur le bord du bureau.*

3. Lift the Cell on the desk stands (two people required) and attach it to the stands with M8 screws. Align the Cell.

4. Ensure that the desk will not tip when the Cell is installed on the desk stands.

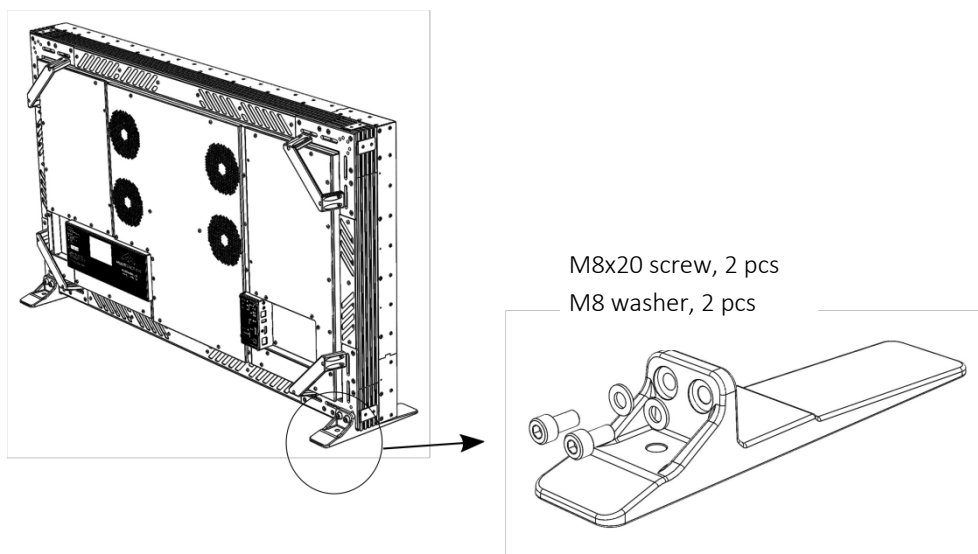

Desk stands and M8 screws

5.4 Multiple-Cell installation

Using the corner mounts and a custom sturdy metal frame, firmly and securely install two or more Cells together to operate in a multiple-Cell configuration.

The weight of individual display should be supported completely by the installation frame. The weight stacking over the under display is not allowed.

Use only the corner M8 mounting holes in multiple-cell installation. Use M8 screws with steel grade 12.9 (Note maximum 14 mm screw depth in the corner M8 mounting holes, ref. chapter 5.).

Ventilation and heat management are especially important in a multiple-Cell installation. You must ensure there is adequate airflow (cool air in and hot air out) through the ventilation slots on each Cell. Leave enough space between the Cells and the wall to allow proper air circulation and cooling. Also, ensure that hot air vented from Cells is directed away from the cool air intakes of adjacent Cells.

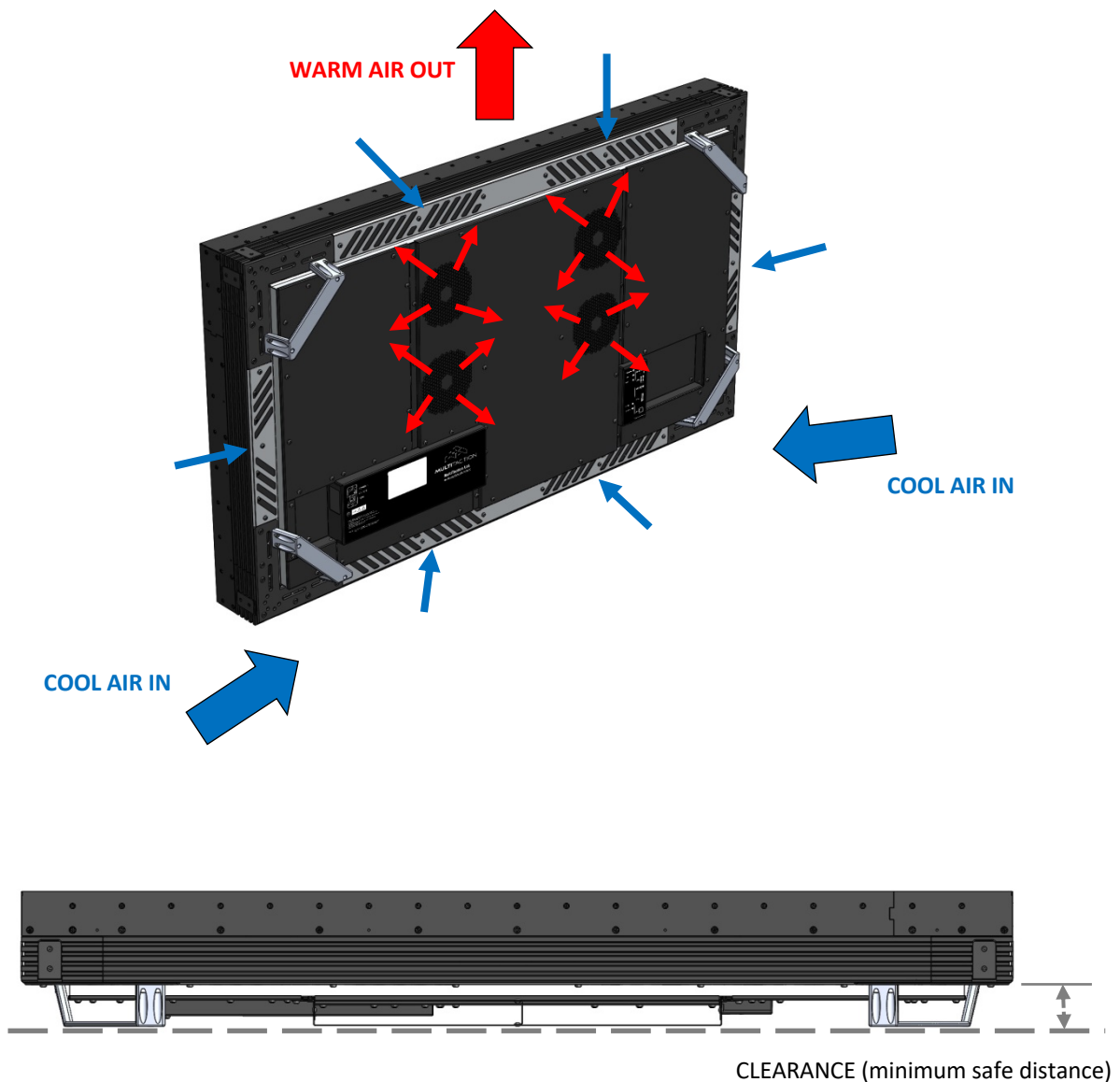

Near wall Installation of MT556XNB

- ❗ **Warning:** *If Cells are installed too close to each other or too close to walls or panels behind the Cells, there is a risk of device overheating. This can cause critical hardware failure and personal injuries. Leave enough space between the Cells and any walls or panels to allow proper air circulation and cooling. The minimum safe distance for a multiple-Cell installation is 51 mm (2 inches).*
- ❗ **Advertissement:** *Les Cellules qui sont installées trop proches les unes des autres ou trop près des murs ou des panneaux arrières, risquent de surchauffer le dispositif, ce qui peut causer une panne critique du matériel et des blessures corporelles. Laisser suffisamment d'espace entre les Cellules et les murs ou les panneaux derrière les Cellules pour permettre une bonne circulation d'air et un bon refroidissement. La distance de sécurité requise pour une installation multiple-Cell est de 51 mm.*

5.4.1 Display wall installations

When planning and implementing display wall installations, remember the technical requirements for heat management of the Cells, *see section 0*.

Ensure that Cells located in one ventilation space have a sufficient intake of cold air. (The typical use for MT556XNB model is 150 m³ per hour per Cell.)

The following example of a 3x3 display wall of MT556XNB Cells provides general guidelines for the design procedure. Each column of three Cells has its own cool air intake and hot air outlet with Air Flow Channels to separating the intake and outlet.

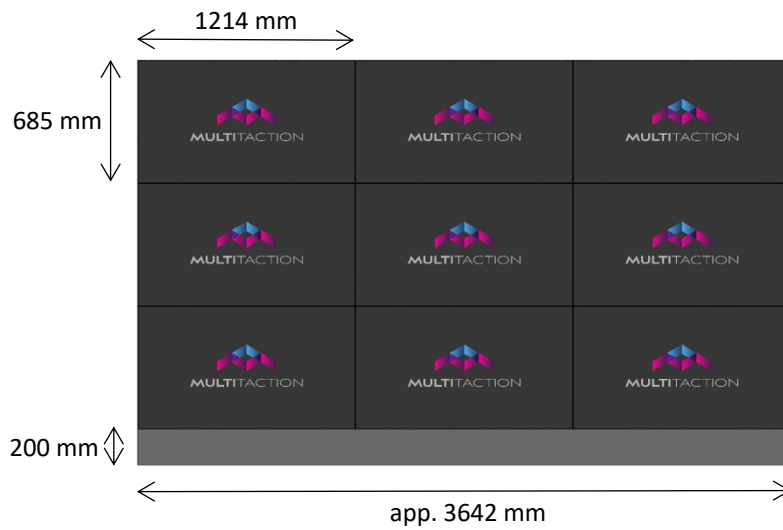

Front view: 3x3 display wall of MT556XNB Cells

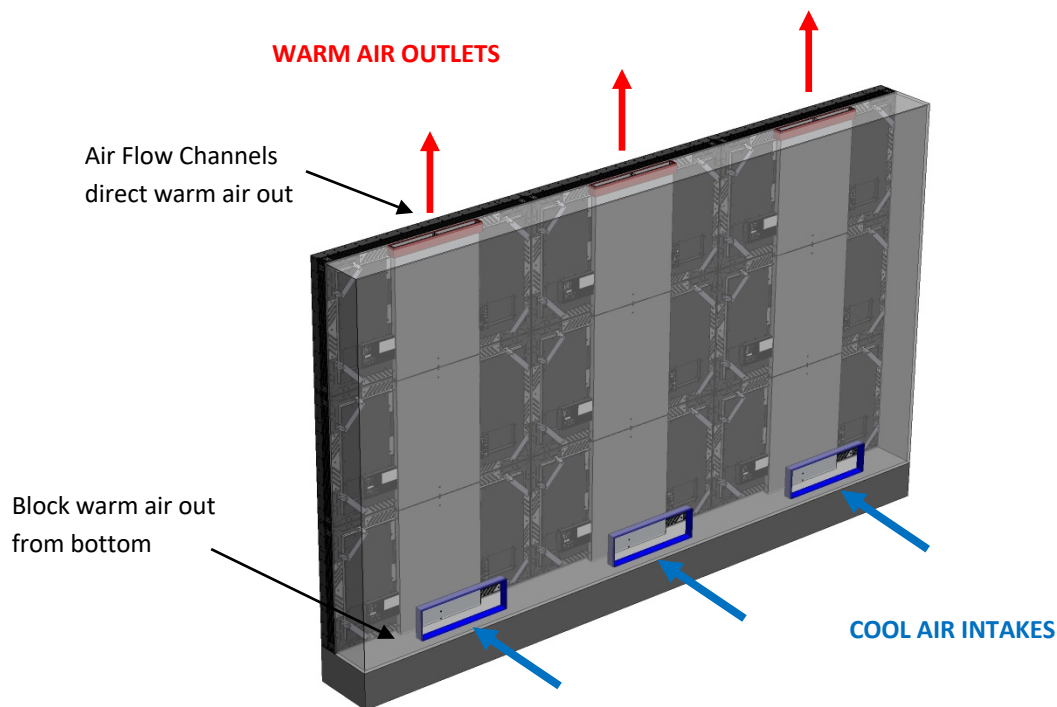

*Isometric view: 3x3 display wall of MT556XNB Cells
 Physical Air Flow Channels direct warm air out*

6 Connect the Cell

The Cell connection panel is located at the back of the device; see [section 2.3](#).

- ⚠ **Warning:** *People can trip over loose and hanging cables, causing personal injuries and damage to the Cell. Route and fasten all cables out of the way.*
- ⚠ **Avertissement:** *Les gens peuvent se trébucher sur des câbles non fixés ou pendants, ce qui peut causer des dommages personnels ou endommager la Cellule. Acheminer et fixer tous les câbles à l'écart.*

6.1 Connections to the mains power supply

To protect Cells from voltage spikes, we recommend that you:

- ⚠ **Warning:** *Always connect Cells to the mains power supply using a 3-wire cord and power strip with a protective earth. Failure to do so may cause an electric shock when using the Cell!*
 - ⚠ **Avertissement:** *Toujours brancher les Cellules sur le bloc d'alimentation électrique à l'aide du cordon à 3 fils et de la multiprise avec un conducteur de protection. Tout manquement peut provoquer un choc électrique en utilisant la Cellule!*
- When connecting other equipment to the Cell, make sure all equipment is disconnected from the mains. Failure to do so may damage the Cell through ground leakage currents from and to other devices.
 - Do *not* connect more than two Cells to a single power strip when connecting them to the mains power supply.
 - Power up the Cells one at a time in multiple-Cell installations.

For Cell power consumption details, see [section A.4 Electrical specifications](#)

MT556XNB	
Power supply	100-240 VAC 50/60 Hz
Mains fuse	Dual Ø5 x 20mm 6.3A 250VAC T (Time-Lag)
Audio	None

 **Note:** Here, a power strip refers to a block of sockets that allows multiple devices to be powered from a single electrical socket. Other common names for a power strip include power bar, power adapter and socket extension, plus many other variations.

 **Remarque:** Une multiprise fait ici référence à un bloc de prises qui permet l'alimentation de plusieurs appareils par une seule prise électrique. On compte parmi les autres noms communs d'une multiprise la prise multiple, le bloc d'alimentation externe et la rallonge, ainsi que de nombreuses autres variations.

 **Caution:** Restrict the number of Cells per mains fuse. The number depends on the rating of the mains electricity supply:

230VAC: Do not connect more than four Cells per mains fuse.

- Countries with 230VAC power include most of Europe, Asia, Africa, and South America, plus Australia and New Zealand.

100-120VAC: Do not connect more than two Cells per mains fuse.

- Countries with 100-120VAC power principally include the US, Canada and Japan.

 **Attention:** Restreindre le nombre de Cellules par fusible secteur. Le nombre dépend du régime nominal de l'alimentation secteur:

230 VCA : Ne pas brancher plus de quatre Cellules par fusible secteur.

- On compte parmi les pays avec l'électricité 230 VCA la plupart des pays européens, l'Asie, l'Afrique, l'Amérique du Sud, l'Australie et la Nouvelle Zélande.

100-120 VCA : Ne pas brancher plus de deux Cellules par fusible secteur.

- On compte parmi les pays avec l'électricité 100-120 VCA les États-Unis, le Canada et le Japon.

6.2 Connections to an external application computer

MultiTaction Cells require an external application computer with two cable connections. While the Cell and application computer are disconnected from the power supply, connect:

Ethernet cable from the Cell to the application computer

An Ethernet cable transmits finger locations and marker information to the application computer. The cable is generally connected to a switch on the LAN so the Cell can use the connection to download firmware updates as necessary. Alternatively, you can connect the Cell directly to the application computer. We do not recommend a wireless connection because of the latency it introduces.

Video cable from the Cell to video outputs on the application computer

This cable enables the video image from the computer to be displayed on the Cell:

MT556XNB: The video cable connects to a DisplayPort video input.

Ensure there is no stress or tension on the connected cables. After connecting all cables, connect the Cell and computer to the mains supply.

 **Note:** For a description of the Cell connection panel, see [section 2.3](#).

 **Remarque:** Pour une description du panneau de connexion de Cellule, voir la [section 2.3](#).

6.3 Connections to the internet

We recommend that all Cells have an internet connection. For this reason, Cells have an Ethernet port for connecting to your default gateway or an external computer; see [section 2.3](#).

If you intend to display Web applications on your Cells, your *application computer* must have an internet connection.

 **Note:** Network settings for the Cell's tracking engine are described online, at address: <https://hardware.multitaction.com/>

 **Remarque:** Les paramètres du réseau du moteur de suivi de la Cellule sont décrits en ligne, à l'adresse: <https://hardware.multitaction.com/>

6.4 USB mouse and keyboard

To show the on-screen display (the OSD), you will need a mouse and keyboard attached to USB ports on the Cell.

For convenience, you may prefer to attach a wireless mouse and keyboard so you can stand in front of the Cell while using the on-screen display.

However, after the OSD appears on-screen, you can configure it to accept finger input. That is, you can use your fingers to configure settings in the OSD.

 **Note:** *You do not need a mouse or keyboard to use the OSD when the Cell first starts up. During start-up, the OSD displays automatically and you can configure it to accept finger input.*

 **Remarque:** *Vous n'avez pas besoin de souris ou de clavier pour utiliser l'OSD au premier démarrage de la Cellule. Pendant le démarrage, l'OSD s'affiche automatiquement et vous pouvez le configurer pour accepter la saisie au doigt.*

6.5 Connections to the SYNC IN / OUT

In the multiple Cell installations, like display walls, the Cells can be synchronize to have same camera capture timing to optimize the tracking engine function. Cells are connected in chain with 3.5 mm plug stereo cable from the one display sync out to the other display sync in; see connectors in [section 2.3](#).

7 Start up the Cell

Follow these steps when you start up the Cell for the first time:

1. Connect the power cable and turn the Cell on with the power switch on the back of the device, *see section 2.3*.
2. Verify the boot sequence.

When you turn the Cell on, confirm that events display in the following sequence:

- a. The MultiTaction 'M' logo briefly appears:



- b. Boot text briefly appears.
- c. The MultiTaction 'M' logo briefly re-appears, this time with a progress bar:



- d. The on-screen display (OSD) briefly appears with a 'Connecting' message:

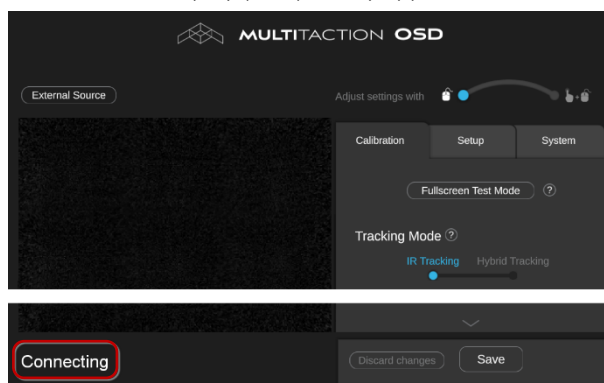

- e. The boot sequence completes when the full OSD appears.
3. Now use the OSD to configure the tracking engine; *see section 8*.

8 Set up the tracking engine

The *tracking engine* runs automatically on the Cell's internal computer. It processes image data captured by the Cell's camera matrix as users touch the screen. The tracking engine then outputs this information as *tracking data* (also called *touch data*) to touch-enabled applications. Tracking data can include fingertip locations, infrared pen locations, plus marker locations and marker code values.

Instructions for configuring the tracking engine are online, at address:

<https://hardware.multitaction.com/>

9 Setting up the application computer

The application computer needs to be set up, so that it can receive touch data from the display and display graphics correctly. Instructions for setting up the application PC are online, at address: <https://hardware.multitaction.com/>

10 Maintenance and cleaning

10.1 Prevent screen burn-in

Caution:

- ⚠ *Static images drawn on-screen for a long period of time can create afterimages that are "burnt" on the display and remain permanently.*
- ⚠ *Run an application that regularly changes the screen's contents, alternating from static images to moving pictures (this helps refresh the display's liquid crystal). Periodical changes in background color and character are also recommended.*
- ⚠ *Enable a screen-saver (with moving pictures or a black pattern).*
- ⚠ *Avoid backgrounds and content with markedly contrasting luminance.*

Attention:

- ⚠ *Les images statiques restant sur l'écran pendant une longue durée, peuvent engendrer des images rémanentes « calcinées » sur celui-ci, y restant en permanence.*
- ⚠ *Exécuter une application modifiant régulièrement le contenu de l'écran, alternant entre images statiques et images animées (ce qui aidera à rafraîchir le cristal liquide de l'écran). Des changements périodiques de la couleur et du caractère du fond, sont également recommandés.*
- ⚠ *Utiliser un économiseur d'écran (avec des images animées ou un motif noir).*
- ⚠ *Éviter en principe les fonds et contenus dont la luminosité contraste nettement.*

10.2 Cell maintenance or repair

Technical maintenance or repair of the Cell must always be conducted by personnel approved by MultiTaction.

Danger:

- ⚠ *Opening the device enclosure causes immediate risk of electrocution, severe personal injury and property damage.*
- ⚠ *Never open the device enclosure.*

Danger:

- ⚠ *L'ouverture du boîtier de l'appareil entraîne un risque immédiat d'électrocution, de blessures graves et de dommages matériels.*
- ⚠ *Ne jamais ouvrir le boîtier de l'appareil.*

10.3 Cleaning the Cell

1. Spray the glass with a standard window cleaning solution, such as Windex® Multi-Surface Cleaner (colorless)
2. Immediately remove the cleaning solution using a lint free cloth

Caution:

- ⚠ *Do not use ammonia-based cleaning solutions*
- ⚠ *Do not use abrasive cleaners*
- ⚠ *Do not use abrasive applicators*
- ⚠ *Do not drench the display surface or edges with the cleaning liquid*
- ⚠ *Do not use scrapers, knives or other sharp or hard objects for cleaning the display glass*

Attention:

- ⚠ *Ne pas utiliser des solutions de nettoyage à base d'ammoniaque*
- ⚠ *Ne pas utiliser de produits nettoyants abrasifs*
- ⚠ *Ne pas utiliser d'applicateurs abrasifs*
- ⚠ *Ne pas mettre de liquide de nettoyage sur la surface d'affichage ou les bords*
- ⚠ *Ne pas utiliser de grattoirs, couteaux ou autres objets pointus ou durs, pour nettoyer le verre de l'écran*

10.4 Warning to service personnel

Warning:

- ❗ *Always connect Cells to the mains power supply using a 3-wire cord and power strip with a protective earth. Failure to do so may cause an electric shock when using the Cell!*
- ❗ *When connecting other equipment to the Cell, make sure all equipment is disconnected from the mains. Failure to do so may damage the Cell through ground leakage currents from and to other devices.*

Avertissement:

- ❗ *Toujours brancher les Cellules sur le bloc d'alimentation électrique à l'aide du cordon à 3 fils et de la multiprise avec un conducteur de protection. Tout manquement peut provoquer un choc électrique en utilisant la Cellule!*
- ❗ *En raccordant d'autres équipements à la Cellule, veillez à ce que tous les équipements soient débranchés du secteur. Tout manquement peut endommager la Cellule par des courants de perte à la terre depuis et vers d'autres appareils.*

Caution to service personnel:

- ⚠ *Double pole / neutral fusing.*
- ⚠ *Maintain with care.*

Attention destine au personnel de service:

- ⚠ *Fusible au neutre / bipolaire.*
- ⚠ *Entretenir avec soin.*

10.5 Replaceable battery

Contact MultiTaction Support for help replacing the lithium battery; see [section 1.1](#).

The battery is positioned in the service access area on the Computer Board. The battery type is CR2032.

- ⚠ **Caution:** *Risk of explosion if the battery is replaced with an incorrect type. Battery should be recycled when possible. Disposal of used batteries must be in accordance with local environmental regulations.*
- ⚠ **Attention:** *Risque d'explosion si la batterie est remplacée par un type incorrect. La batterie doit être si possible recyclée. L'élimination des piles usagées doit se faire en conformité à la réglementation environnementale locale.*

Appendix A. Technical specifications

A.1 Display

MT556XNB	
Display technology	TFT LCD ultra-thin bezel
Display size	55" 16:9 wide
Native Resolution	Full HD 1920 x 1080
Display Colors	16.7 million
Display Active Area	1209 x 680 mm
Pixel Pitch	0.63 x 0.63 mm
Pixel Response Time	8ms gray to gray
Brightness	700 cd/m ²
Contrast Ratio	4000:1 typical
Picture Frame Rate	60 Hz
Backlight	White LED matrix array
Viewing angle	178° (horizontal and vertical)

A.2 Touch sensing hardware

MT556XNB	
Touch technology	Clearsight touch
Tracking speed	120 fps
IR source and camera	Integrated Backlight Emitter Camera modules
IR wavelength	850 nm

A.3 Interfaces

MT556XNB	
Video input	DisplayPort 1.1
Control input	Ethernet USB Type-A
Keyboard and mouse input	3 x USB 2.0 Type-A
Power connector	IEC C14

A.4 Electrical specifications

MT556XNB	
Power supply	100-240 VAC 50/60 Hz
Mains fuse	Dual Ø5 x 20mm 6.3A 250VAC T (Time-Lag)
Audio	None

A.5 Power consumption

MT556XNB	
Typical	350W
Maximum	400W
Standby	33W

A.6 Touch details

MT556XNB	
Tracking Software	Clearsight Touch Tracking Engine
Interaction methods	Single finger, multiple fingers, single hand, multiple hands and users, objects with optical markers, basic shapes, infrared pen. Click, hold and drag.
Hand recognition	For each finger, its orientation is recognized and it is identified as belonging to a specific hand.
Object recognition (infrared pen)	Supported with 2D fiducial markers and some basic shapes. Unlimited simultaneous infrared pen and touch input.
Number of simultaneous touch Inputs	Unlimited
Number of simultaneous users	Unlimited (separate hands)
Positional accuracy	2mm, directional compensation
Relative accuracy	Sub-pixel accuracy
Touch latency	10 ms typical. Measured from touch to processed tracking data output. Overall latency is higher and depends on the computer, operating system, and application being used.
Tracking data outputs / APIs	Multi-Format Tracking Output: Low level C++, TUIO, XML stream Windows 10 Touch (<i>MT556XNB only</i>)
Operating system support	Windows 10; Linux Ubuntu; Mac OS X
Development environment support	Most major programming languages and environments (SDK, TUIO-compatible systems). See MultiTaction Cornerstone documentation for further details: https://developer.multitaction.com/
Software Development Kit	Cornerstone 2.1 SDK available for C++/OpenGL (Windows 10, Linux, Mac OS X)
Stackability	Any number of Cells can be stacked to run a single multi-touch application.

MT556XNB

However, up to 32 of Cells for an individual computer is limited by the computer's configuration.

A.7 Environment

MT556XNB

Operating temperature	0 to +35 °C
Storage temperature	-10 to +60 °C <i>Allow at least two hours for temperature normalization before switching on the unit.</i>
IP rating	20
Relative humidity	Non-condensing 80%

A.8 Dimensions and weight

MT556XNB

Size (WxHxD)	1214 x 685 x 165 mm
Mullion	≤ 4.5 mm pixel to pixel
Weight	34 kg (75 lbs) plus 1 kg for two legs
Color	Black RAL9005

A.9 Display mounting

MT556XNB

VESA Mount	Corner Mounted, M8 screws 800 x 400 mm, M8 screws (optional adapter needed)
Mounting positions	Vertical Horizontal Angled position Table position Display Array (2-32 units) Symmetric or asymmetric layouts

A.10 Cooling

MT556XNB	
Cooling system	Forced air convection
Convection method	Low noise, variable speed internal fans

A.11 Ventilation

MT556XNB	
Air passing through Cell	
Typical amount	150 m ³ per hour (at NTP conditions)
Maximum amount	300 m ³ per hour

A.12 Miscellaneous

MT556XNB	
Agency approvals	CE, FCC, ICES, CCC
RoHS compliant	Yes
Expected lifetime	Over 50,000 h
Warranty	3 year limited

FCC compliance

Product Name	MULTITACTION
Model number	MT556XNB

This device complies with part 15 of the FCC Rules. Operation is subject to the following two conditions:

- This device may not cause harmful interference, and
- this device must accept any interference received, including interference that may cause undesired operation.

[MultiTitaction Americas, Inc.](#)

1450 Arthur Avenue, Unit A, Elk Grove Village, IL 60007

Phone number: 1-888-716-8584

[Radio and television interference](#)

This equipment has been tested and found to comply with the limits for a Class B digital device, pursuant to Part 15 of the FCC rules. These limits are designed to provide reasonable protection against harmful interference in a residential installation. This equipment generates, uses and can radiate radio frequency energy and, if not installed and used in accordance with the instructions, may cause harmful interference to radio communications. However, there is no guarantee that interference will not occur in a particular installation. If this equipment does cause harmful interference to radio or television reception, which can be determined by turning the equipment off and on, the user is encouraged to try to correct the interference by one or more of the following measures:

- Reorient or relocate the receiving antenna.
- Increase the separation between the equipment and the receiver.
- Connect the equipment into an outlet on a circuit different from that to which the receiver is connected.
- Consult the dealer or an experienced radio/TV technician for help.

Changes and Modifications not expressly approved by the manufacturer or registrant of this equipment can void your authority to operate this equipment under Federal Communications Commission rules.

Warranty service policy and procedures

Models

This warranty applies to the following models:
MT556XNB

Definitions

- **Authorized Reseller** — A reseller authorized by MultiTaction to sell the Products.
- **Buyer** — The first purchaser of a Product or Products from MultiTaction or Authorized Reseller.
- **MultiTaction** — MultiTaction Ltd. and its subsidiaries.
- **Product or Products** — Multi-touch displays manufactured by MultiTaction, which are branded as MultiTaction Cell.

General Terms and Conditions

1. The Products carry a limited warranty for a period of twelve (12) months, applicable from the date of delivery of the Products to the Buyer by MultiTaction or by Authorized Reseller, as the case may be.
2. This limited warranty covers only the Products. It does not cover software or non- MultiTaction Cell- or MultiTaction Cell-branded products.
3. This warranty is valid only when Buyer either presents proof of purchase consisting of original invoice or sales slip indicating the date of purchase, model and serial number of this Product, or properly completes and presents the warranty card, indicating the date of purchase, the name of the Authorized Reseller, the model of this Product, and the serial number of this Product. MultiTaction reserves the right to refuse warranty if this information has been removed, obliterated, or altered after the original purchase of this Product from MultiTaction or the Authorized Reseller, where applicable. Buyer shall notify MultiTaction in writing of the claimed defects and demonstrate to MultiTaction's satisfaction that said defects are covered by this limited warranty.
4. MultiTaction 's obligations are limited to repair of the defect or replacement of the defective part or, at its option, replacement of this Product itself.
5. Only MultiTaction Authorized Resellers may carry out warranty repairs. Warranty is void if any unauthorized service provider has attempted repair. MultiTaction shall not be liable for reimbursements, claims, or damages that may result from any unauthorized repair of this Product.
6. Repair or replacement under the terms of this warranty does not provide Buyer a right to extend or renew the warranty period. Repair or direct replacement of this Product under the terms of this warranty may be fulfilled.
7. The warranty is only applicable to defects in material, design and workmanship of this Product.
8. By way of an example only, and not as a limitation, the warranty does not cover the following, unless specifically authorized in writing by MultiTaction:
 - Periodic checks, maintenance, repair and replacement of parts due to normal wear and tear;
 - Abuse or misuse, including but not limited to the failure to use the Product for its normal purposes or in accordance with MultiTaction 's instructions on usage and maintenance;
 - Any damage caused by the combination of this Product with other products;
 - Any damage resulting from the interaction of this Product with any software or hardware, including, but not limited to, loss or corruption of data;
 - Any damage caused to the Product by viruses or other types of malicious code, or malicious intrusion;

- Failure or malfunction of this Product arising from incorrect or improper installation or use not consistent with the instructions and technical or safety standards prescribed in the user manual associated with this Product;
 - Accidents, acts of nature such as lightning, water, and fire, public disturbances, improper ventilation, voltage fluctuations, or any other cause beyond the reasonable control of MultiTaction;
 - Unauthorized modifications of this Product for the purpose of complying with local or international technical standards in countries for which this Product was not originally designed or intended;
 - Any of the seals on this Product's enclosure or parts are broken or show evidence of tampering;
 - Defects caused to this Product by improper use as determined by MultiTaction;
 - Modification or alteration of any nature that is made in the electrical circuitry/ or physical construction of this Product;
 - Installation/ repair work on this Product that is carried out by persons/agency other than those authorized by MultiTaction;
 - Site (premises where this Product is kept) conditions that do not conform to the recommended operating conditions of this Product;
 - Defects occurring while this Product is in transit;
 - Damage to and/or removal of the protective glass/plastic of this Product after Buyer has received this Product; or
 - When this Product is leased, rented, loaned, or given as promotion, either by MultiTaction or by Buyer.
9. This warranty does not affect either the consumers' statutory rights or the consumers' rights against the Authorized Reseller related to their purchase/sales agreement.
 10. This warranty is not transferable or assignable. This warranty will be Buyer's sole and exclusive remedy and neither MultiTaction nor its Authorized Resellers shall be liable for any incidental or consequential damages or breach of any express or implied warranty of this Product. DISCLAIMER: MultiTaction shall not be liable for the loss of any saved/stored data in Products that are either repaired or replaced.
 11. This warranty is exclusive. The sole and exclusive obligation of MultiTaction is to repair or replace the defective Product in the manner and for the period provided above. MultiTaction shall not have any other obligation with respect to this Product or any part thereof, whether based on contract, tort, and strict liability or otherwise. Under no circumstances, whether based on this limited warranty or otherwise, shall MultiTaction be liable for incidental, special or consequential damages.
 12. Oral or written statements made by MultiTaction's employees or representatives DO NOT CONSTITUTE WARRANTIES, and shall not be relied upon by Buyer, and are not a part of the contract for sale or this limited warranty.

The above policies are for Product warranty service and Buyer will be responsible for any costs associated with non-warranty conditions MultiTaction reserves the right to make final decisions regarding problem determination and the appropriate service option. Replacement units assume the remaining warranty of the original Product.

Limited Warranty Statement for MultiTaction Products

1. Only MultiTaction Authorized Resellers may carry out repairs or replacements.
2. In the event of repairs/replacement of any part/s of this Product, this warranty will thereafter continue and remain in force only for the unexpired period of the warranty. Moreover, the time taken for repair/replacement and in transit whether under the warranty or otherwise shall not be excluded from the warranty period.

3. MultiTaction or an Authorized Reseller reserves the right to retain any part/s or component/s replaced at its discretion in the event of a defect detected in this Product during the warranty period.
4. Buyer must communicate any change of address to either MultiTaction or concerned Authorized Reseller in writing for the continuation of warranty.
5. Warranty for the unexpired period shall continue after this Product is inspected by either MultiTaction or the concerned Authorized Reseller, as the case may be, and found free from transit damage.
6. In case of any transit damage, this Product shall be repaired and the repair shall be invoiced by either MultiTaction or the Authorized Reseller in question, as the case may be, and warranty for the unexpired period shall continue.
7. The warranty does not cover the use of the Product(s) for demonstration purposes.
8. The warranty does not cover accessories external to this Product.

The Authorized Reseller with whom this Product is registered for warranty service, or MultiTaction, where applicable, will instruct Buyer as to whether to effect the warranty service on site at Buyer's premises or at the premises of either Authorized Reseller or MultiTaction. If warranty service is effected at the premises of either Authorized Reseller or MultiTaction, warranty service shall be carried out on a "Carry In" basis, wherein Buyer shall, based on the instructions it has received, bring this Product to either Authorized Reseller or MultiTaction. If warranty service is effected at Buyer's premises, Buyer shall pay a visiting charge, including all travel costs such as flights and other transportation, accommodation, daily travel expense allowances and other travel-related costs related to warranty service, as applicable. The warranty does not cover cost of transportation of a Product from place of installation to MultiTaction or the Authorized Reseller, as the case may be.

Limited Warranty Statement Extension Concerning Dead Pixels in LCD Based Products

Each MultiTaction LCD based Product may have a maximum of one (1) non-significant dead pixel in LCD panel after manufacturing. During the warranty period a maximum of six (6) non-significant dead pixels are permitted without the need for any repair or replacement of the LCD panel covered by the warranty.

In the event of repairs/replacement of any part/s of the unit, this warranty will thereafter continue and remain in force only for the unexpired period of the warranty. Moreover, the time taken for repair/replacement and in transit whether under the warranty or otherwise shall not be excluded from the warranty period.

Limited Warranty Statement Extension Concerning Image Retention/Burn-In in LCD Based Products

Damage to MultiTaction LCD-based Products caused by so-called image-retention or image burn-in is NOT covered by this warranty. Please ensure that the precautions in any documentation supplied with the Product are followed in order to avoid permanent damage to it.

Disclaimer

THERE ARE NO EXPRESS WARRANTIES OTHER THAN THOSE LISTED AND DESCRIBED ABOVE, AND NO WARRANTIES WHETHER EXPRESS OR IMPLIED, INCLUDING, BUT NOT LIMITED TO, ANY IMPLIED WARRANTIES OF MERCHANTABILITY OR FITNESS FOR A PARTICULAR PURPOSE, SHALL APPLY AFTER THE EXPRESS WARRANTY PERIODS STATED ABOVE, AND NO OTHER EXPRESS WARRANTY OR GUARANTY GIVEN BY ANY PERSON, FIRM OR CORPORATION WITH RESPECT TO THIS PRODUCT SHALL BE BINDING ON MULTITACTION. MULTITACTION SHALL NOT BE LIABLE FOR LOSS OF REVENUE, PROFITS, OR DATA, FAILURE TO REALIZE SAVINGS OR OTHER BENEFITS, OR ANY OTHER SPECIAL, INCIDENTAL OR CONSEQUENTIAL DAMAGES CAUSED BY THE USE, MISUSE OR INABILITY TO USE THIS PRODUCT, REGARDLESS OF THE LEGAL THEORY ON WHICH

THE CLAIM IS BASED, AND EVEN IF MULTITACTION HAS BEEN ADVISED OF THE POSSIBILITY OF SUCH DAMAGES. NOR SHALL RECOVERY OF ANY KIND AGAINST MULTITACTION BE GREATER IN AMOUNT THAN THE PURCHASE PRICE OF THIS PRODUCT SOLD BY MULTITACTION AND CAUSING THE ALLEGED DAMAGE. WITHOUT LIMITING THE FOREGOING, BUYER ASSUMES ALL RISK AND LIABILITY FOR LOSS, DAMAGE OR INJURY TO BUYER AND PURCHASER'S PROPERTY AND TO OTHERS AND THEIR PROPERTY ARISING OUT OF THE USE, MISUSE OR INABILITY TO USE THIS PRODUCT SOLD BY MULTITACTION NOT CAUSED DIRECTLY BY THE NEGLIGENCE OF MULTITACTION. THIS LIMITED WARRANTY SHALL NOT EXTEND TO ANYONE OTHER THAN THE ORIGINAL BUYER OF THIS PRODUCT, IS NONTRANSFERABLE AND STATES YOUR EXCLUSIVE REMEDY.